

## REVIEW ARTICLE

# Root Canal Curvatures: A Literature Review

Smita Agrawal<sup>1</sup>, Swapna.D.V<sup>2</sup>, Roopa. R Nadig<sup>3</sup>, Bijo Kurian<sup>1</sup>**ABSTRACT**

Preparation of curved root canals during endodontic treatment poses a great challenge. Appropriate diagnosis of the curvature of the root canal and selecting specialised instrumentation technique is pre requisite for successful treatment of curved canals. So the measurement of degree of curvature and knowledge of the complex internal anatomy are mandatory to reduce endodontic failure rates. The aim of the present literature survey was to present and evaluate existing canal curvature measuring techniques.

**Keywords:** Root canal, Endodontics, Curvature

**How to cite this article:** Smita Agrawal, Swapna.D.V, Roopa.R Nadig, Bijo Kurian. Root Canal Curvatures: A Literature Review. International Journal of Contemporary Medical Research. 2015;2 (2):214-219

<sup>1</sup>Post graduate student, <sup>2</sup>Reader, <sup>3</sup>Professor & HOD, Department of Conservative Dentistry and Endodontics, Dayananda Sagar College of Dental Sciences, Bangalore India

**Corresponding author:** Dr. Smita Agrawal, PG Student, Department of Conservative Dentistry and Endodontics, Dayananda Sagar College of Dental sciences, Bangalore, Karnataka, India

**Source of Support:** Nil

**Conflict of Interest:** None

**INTRODUCTION**

A tooth with root curvature is a normal finding rather a straight root and straight root canal is considered to be an exception.<sup>1</sup> It is important to be familiar with variations in tooth anatomy because, such knowledge can aid location and negotiation of canals as well as their subsequent management. Endodontic treatment consists of different stages including access cavity preparation, instrumentation, irrigation, obturation of root

canal system which can all be influenced by root canal curvature.<sup>3</sup> Although the development of new methods and improved instruments has led in recent decades to marked progress in root canal preparation, the shape and direction of the original long axis of curved canals are still susceptible to changes during preparation. One criterion for assessment of the preparation quality of curved root canals is preparation-induced straightening of the canal.<sup>4</sup>

The most common factor accounting for preparation-induced deviations from the original axis is inadequate flexibility of the instruments used for preparation. Curvature in the roots invariably led to the development of various preparation instruments. With a flexibility 2-3 times higher than that of stainless steel files, nickel-titanium (NiTi) files are helpful in the preparation of curved canals. Therefore it is imperative that one should be aware of the various methods of measuring the root canal curvature as it aids in the selection of the type of instruments and techniques used in endodontic therapy.<sup>4</sup> This literature review describes and discusses different measuring techniques to evaluate canal curvature.

**METHODS TO MEASURE ROOT CANAL CURVATURES****Angular measurement for determination of canal curvature***SCHNEIDER METHOD*

In 1971, Schneider was the first to measure the root curvature mathematically. It is still used worldwide due to its practicality and simplicity. Schneider determined the curvature angle in relation to long axis of the tooth, and divided the degree of curvature of root canals into three categories: Straight (<5°), Moderate (10°-20°) and Severe (25°-70°).

A line was scribed on the radiograph parallel to the long axis of the canal (Fig.1). A second line

was drawn from the apical foramen (AF, point B) to intersect with the first at the point where the canal began to leave the long axis of the tooth (Point A). These two lines intersected at angle (X) as a measure of the change in direction of the long axis of the canal in relation to the long axis of the tooth (Fig-1). The disadvantage of this technique was that, it treats the long axis of teeth as equivalent to that of the root canal and the curvature of root canal between point A and point B cannot be determined. In molars the point where the two stated lines intersect ie; where the line leaves the long axis of the tooth is not defined and that curvature of s- shaped canals cannot be determined.<sup>9</sup>

### LUITEN TECHNIQUE

Luiten et al used long axis of the canal for the measuring the canal curvature, two lines were drawn whose correct geometric definition was given by four points (Fig. 2). The first point is at the centre of the canal orifice (Point A). The second point is 2 mm below the orifice in the long axis of the canal (Point B). A line is drawn through Points A and point B. In the apical third of the root, the apical foramen forms Point D. Another point, Point C located 1 mm further coronal in the long axis of the canal, is selected to allow the second line to be drawn through the two points. The two lines through Points A & B and Point C & D, intersect at angle X.

In many of root canal preparations, Gates Glidden burs are used for preflaring the coronal third of the canal. The shape of the canal orifice and thus the position of Points A and B is thus partially determined by the shape and size of the instruments used for preflaring.

The disadvantage of this method is that, using two apical points are too close together to permit a reproducible line to be determined with certainty. In consequence, the angle measured by this method for the change in direction of the long axis of the canal is highly dependent on the reliable construction of Points A to D.<sup>11</sup>

Pettiette et al introduced a new parameter described as the "curvature radius" for measuring root canal curvature. The technique is similar to that presented by Luiten et al. However, the points through which the lines are

drawn (Fig. 2) are farther apart. The first point is formed by the centre of the canal orifice (Point A). The second point is located at the end of the coronal third of the canal (Point B). Point C is at the start of the apical third of the root and Point D is formed by the apical foramen. The lines through Points A & B and C & D intersect at angle alpha. These lines met at an angle that was defined as canal angulation ( $\alpha$ ), representing the degree of deviation of the apical axis from the coronal one.<sup>7</sup>

### WEINE'S METHOD

A straight line is drawn from orifice through the coronal portion of curve and second line drawn from apex through apical portion of curve. The intersection of two lines form the canal angulation.<sup>16</sup>

### LONG AXIS TECHNIQUE

Hankin et al used the long axis of the tooth to measure the canal curvature. The LA technique involves drawing a line passing through the apical one-third of the canal; the angle formed by the intersection of that line with the long axis of the tooth is known as the LA angle.<sup>4</sup>

### CANAL ACCESS ANGLE

The canal orifice (A) and apex (B) points were connected with a line. The angle formed by the intersection between this line (AB) and one drawn parallel to the long axis of the canal from the coronal part (AC) (used in the Schneider method), is defined as the CAA. At the point (C) where the parallel line described in the Schneider method leaves the root canal a perpendicular line was drawn to AB. The point that the perpendicular line intersects AB is D. CD gives the curvature height (x), and the distance from A to point D is the CURVATURE DISTANCE (AD=y).

### MEASUREMENT OF MULTIPLE ROOT CANAL CURVATURES

A method for measuring the multiple curvatures in s-shaped canal configuration was published by

Cunningham and Senia. In this the angle for both the coronal and the apical portion of the canal was determined (Fig. 5) from the straight position of the canal. A line is drawn through Points A and B. A second line is drawn from Point B to the point at which the canal starts to deviate again from the long axis of the tooth (Point C). The angle formed by the intersection of the two lines is measured as the canal curvature. A further line is drawn from Point C to the apical foramen (Point D). The angle at which the lines through Points B & C and C & D intersect yields angle Y for the change in direction of the canal in the apical section.

The advantages of this technique over Schneider method is that, multiple curved canals can be described and the canal deviation is determined in relation to the actual configuration of the canal.<sup>10</sup>

#### **GRAPHIC AND MATHEMATICAL DETERMINATION OF CHANGES IN ANGLE**

Berbert and Nishiyama presented a technique containing a mathematical component in addition to the graphic determination of the change in direction of the long axis of the canal. The first measuring point (A) is 2 mm apical to the reference line at the base of the pulp cavity. Point (B) is located 1 mm short of the apical foramen. Measuring points A and B, which are needed for construction of lines a and b are 1 mm respectively closer to the centre of the canal than points A and B. Angle X resulting at the intersection point of the two lines a and b in Point C, which describes the angle formed by the change in direction of the long axis of the canal. A quotient is formed by dividing the stated lines into two defined sections. The length of section AC and that of section BC are determined. The length of section AC and that of section BC are determined. A quotient is calculated by dividing section BC by section AC. The size of this quotient permits conclusions to be drawn on whether the maximum curvature is in the upper, central or lower third of the root. The quotient is < 0.5 if the curvature is in the cervical third; between 0.5 and 2 if the curvature is in the central

third; and >2 if the curvature is in the coronal third of the root.<sup>12</sup>

This technique describes the location of maximum root curvature and a potential improvement for the description of preparation induced changes in curvature.

#### **Angle and radius of curvature for the determination of canal curvature**

##### *Pruett et al. method*

Pruett et al developed a method supplementing angular measurement according to Schneider with the graphically determined curvature radius as a further parameter (Fig.7). This has permitted the geometrically correct description of a curvature for the first time.

Two lines are drawn along the long axis of the coronal and apical portion of the tooth. There is a point on each of these lines where the canal deviates to begin (Point A) or end (Point B) the canal curvature. The centre of the circle is thus at the point where the vertical lines intersect the tangents through A and B.<sup>13</sup>

##### *Schafer et al. technique*

Schafer et al modified Pruett et al method. In this, the radius of the hypothetical circle defining the curved part of the canal. The line between Point A and B is a chord of the hypothetical circle that defines the curved part of the canal. The curved part of the root canal between Point A and B is the circular arc of the hypothetical circle which is specified by its radius (r). The radius could be calculated on the basis of the measured length of the chord between points A and B.<sup>14</sup>

The methods introduced by Pruett et al. and by Schafer et al, examined different areas of the root canal, with Pruett et al describing curvatures in the central part of the canal and Schafer et al in the apical part

#### **Computer-aided Determination Of Root Curvatures**

The first authors to describe root curvature in a mathematically correct manner were Nagy et al. All known canal configurations can be examined

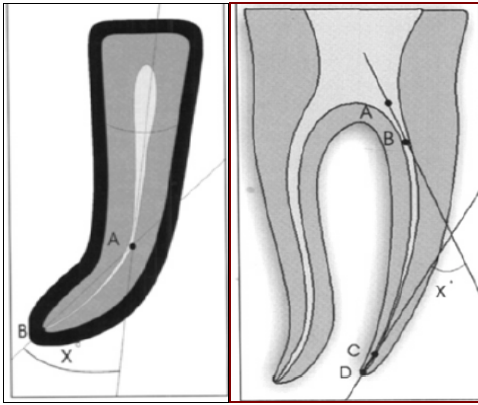

**Figure-1:** Schneider Method; **Figure-2:** Luiten Technique

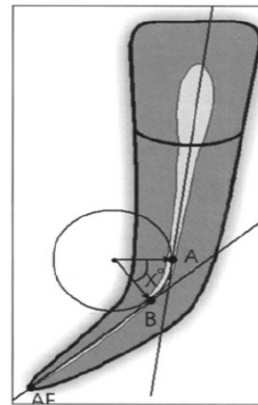

**Figure-7:** Pruett Method

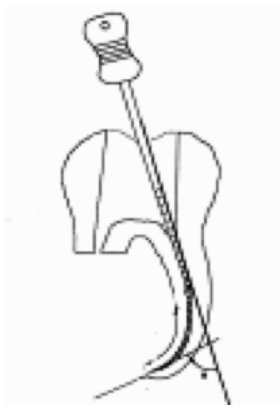

**Figure-3:**  
Weine's  
Method

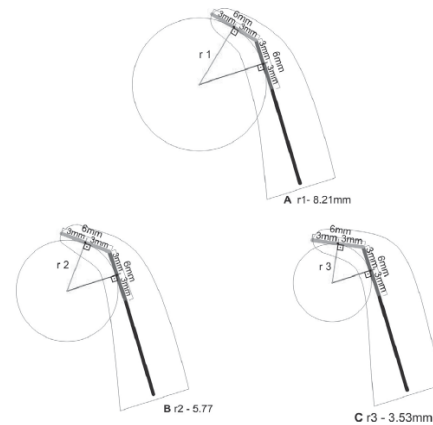

**Figure-8:** CBCT Technique

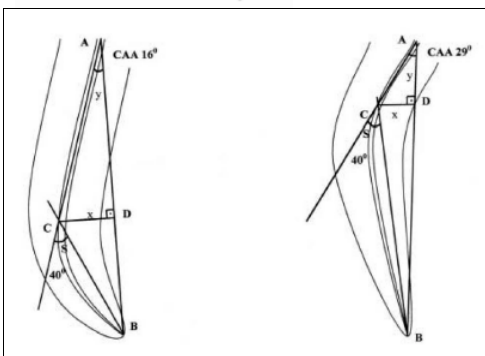

**Figure-4:** Canal Access Angle

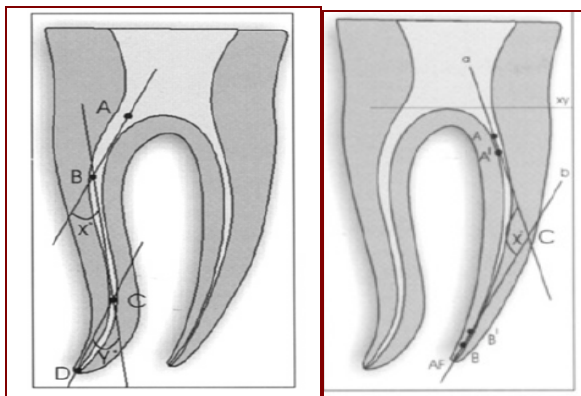

**Figure-5:** Cunningham and Senia Method; **Figure-6:** Graphic and mathematical determination of changes in angle

using this method . The authors fixed the first measuring point at the apical foramen and determined six further points as far as the pulp cavity orifice along the centre-line of the long axis of the canal. Five of these seven points were located in the apical third of the root, where the largest curvatures were to be expected. The coordinates of the marked points were fed into a computer and the curvature was determined with a fourth-degree polynomial function. Finally the correlation between the calculated and the digitised measuring points was verified and a degree of accuracy was specified.<sup>6</sup>

### Three-dimensional Determination Of Root Curvature

All the above methods the canal configuration is evaluated in only two dimensions Hence currently, three dimensional representation of the canal morphology is playing an increasingly important role in curvature determination.

### Three-dimensional determination of the imaginary root canal axis

By cutting a tooth open and taking ninety-degree turn around image pairs of the long axis of the canal, Harlan et al introduced a method permitting a three-dimensional canal configuration to be reproduced mathematically from a pair of two-dimensional images. This technique enabled the spatial imaginary root canal axis to be determined before and after canal preparation. However, this technique involved the destructive process of taking the tooth apart and fitting it together again for preparation purposes.

### Cone beam computed tomography

CBCT which provides detailed high-resolution images of oral structures. The accuracy of CBCT images to identify anatomic and pathologic alterations compared to panoramic and periapical radiographs has been shown to reduce the incidence of false-negative results.

The propose method to determine the curvature radius of curved root canal uses two 6-mm semistraight lines superimposed to the root canal, the primary line (light gray) being the one that represents the longer continuity of the apical region and the secondary line (dark gray) being the one that represents the middle and cervical thirds. Regardless of the length of the secondary line, only the 6 mm closest to the primary line is used to measure. The midpoint of each semi straight line is determined. From this spot, two lines perpendicular to the semistraight lines are drawn until they meet at a central point, which is named circumcenter.

The distance between the circumcenter and the center of each semistraight line is the radius of the circumference, which determines the magnitude of the curve.<sup>16</sup> The root curvature based on 3 mathematical points can be determined in both apical and coronal direction. Curvature radius considering the two 6mm semistraight lines are classified as small radius ( $r \leq 4\text{mm}$ ):severe curvature; intermediary radius ( $r \geq 4\text{mm}$  and  $r \leq 8\text{mm}$ ): moderate curvature; and large radius ( $r \geq 8\text{mm}$ ): mild curvature.

### Microcomputed Tomography

Micro computed tomography (MCT) is a technique permitting non-destructive three-dimensional representation of the canal lumen. This technique offers numerous opportunities for in vitro investigations. Preparation induced trans-portations and shifts in the long axis of the canal can be determined. Peters et al used MCT to investigate the canal volume canal surface after preparation. The preparation-induced change in curvature can be calculated and a mean preparation-induced canal straightening rate of approximately 4%. In view of the available database, evaluation of straightening presents no problem with this method. However, the cost-intensive technique and the time consuming data generation are factors currently opposing a rapid spread of this technique.<sup>17,18</sup>

### CONCLUSION

Measurement of root canal curvature should consider both angular and radius of curvature measurement, which will provide information about the abruptness of canal curvature and thereby allows more accurate planning of root canal instrumentation. Recently computer aided evaluation technique are used extensively to determine the curvature in section of the root canal. Micro computer tomography permits extremely precise evaluation, but, this involves more radiation exposure hence, Microcomputer tomography is more suitable for lab research only. More recently, CBCT has turned out to be a more valid aid in determining root canal curvature. Since, this method is non-distractive, faster and less radiation dose as compared to micro CT, it is certainly of great value for in vivo analysis in cases of extreme curvatures.

### REFERENCES

1. Cohen S, Burns RC. Pathways of the pulp. 8th ed. St Louis: Mosby, 2002:94, 243–74
2. Hamid Jafarzadeh, and You-Nong Wu. The C-shaped Root Canal Configuration: A Review . JOE — Volume 33, Number 5
3. Cohen S, Burns RC. Pathways of the pulp. 8th ed. St Louis: Mosby, 2002:94, 243–74,

4. Sadeghi S, Poryousef V. A novel approach in assessment of root canal curvature. *IEJ*;2009; 4:4-6
5. Gunday M, Sazak H, Garip Y. A comparative study of three different root canal curvature measurement techniques and measuring the canal access angle in curved canal. *JOE* 2005;31:11
6. Sanntag D, Stachniss-carp S, Stachniss V. Determination of root canal curvatures before and after canal preparation (part 1): A literature review. *AEJ* 2005;31:3-8
7. Nagy C S, Szabo J, Szabo J. A mathematical based classification of root canal curvatures on natural human teeth. *JOE* 1995;21:11-8
8. Pettiette MT, Metzger Z, Phillips C, Trope M. Endodontic complications of root canal therapy performed by dental students with stainless steel K-files and nickel-titanium hand files. *J Endod* 1999; 25:30:34-38
9. Stropko J. Canal morphology of maxillary molars: clinical observations on canal configurations. *J Endodon* 1999;25:446-50.
10. Schneider SW. A comparison of canal preparations in straight and curved root canals. *Oral Surg Oral Med Oral Pathol* 1971;32: 271-5.
11. Cunningham CJ, Senia ES. A three-dimensional study of canal curvatures in the mesial roots of mandibular molars. *J Endod* 1992; 18:294-300.
12. Luiten DJ, Morgan LA, Baugartner JC, Marshall JG. A comparison of four instrumentation techniques on apical canal transportation. *J Endod* 1995; 21:26-32.
13. Berbert A, Nishiyama CK. Curvaturas Radiculares. Uma Nova Metodologia Para a mensuração e Localização. *Rev Gau Alegre* 1994; 42:356-58.
14. Pruett JFI, Clement DJ, Carnes DL Jr. Cyclic fatigue testing of nickel-titanium endodontic instruments. *J Endod* 1997
15. Schafer E, Diez C, Hoppe W, Tepel J. Roentgenographic investigation of frequency and degree of canal curvatures in human permanent teeth. *J Endod* 2002, 28: 211-16
16. Dobó-Nagy C, Keszthelyi G, Szabo J, Sulyok FI, Ledeczky G, Szabo J. A computerised method for mathematical description of three-dimensional root canal axis. *J Endod* 2000;
17. Zhu et al. Reliability of two methods on measuring root canal curvature. *Int Chin J Dent*;2003;3:118-121
18. Peters OA, Schonenberger K, Laib A. Effects of four NiTi preparation techniques on root canal geometry assessed by micro-computed tomography. *Int Endod J* 2001;34: 221-30